

CAST IRON GATE VALVES

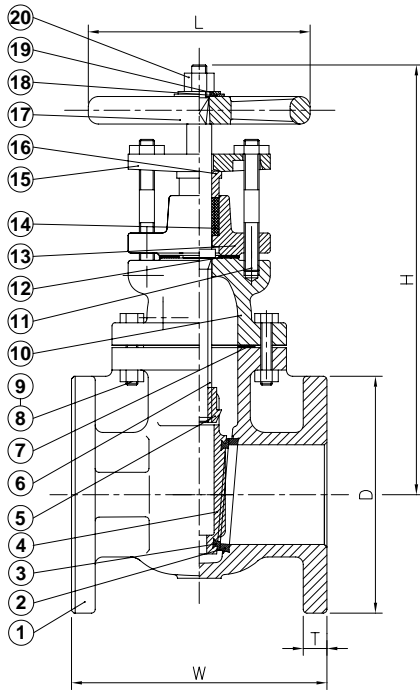

SERIES 550

CLASS 125, FLANGED ENDS (TO ANSI B16.1), BOLTED BONNET, NON-RISING STEM, FACE-TO-FACE DIMENSIONS TO ANSI B16.10, MSS SP-70 DESIGN, SIZE:2"~16".



MATERIALS LIST:

NO.	PART	SPECIFICATION
1	BODY	ASTM A126 CLASS B
2	SEAT RING	ASTM B62
3	WEDGE FACE RING	ASTM B62
4	WEDGE	ASTM A126 CLASS B
5	WEDGE NUT	ASTM B62
6	STEM	ASTM B16
7	BODY GASKET	NON ASBESTOS
8	BOLT	ASTM A307-B
9	NUT	ASTM A307-B
10	BONNET	ASTM A126 CLASS B
11	GLAND FOLLOWER BOLTS	ASTM A307-B
12	STUFFING BOX GASKET	NON ASBESTOS
13	STUFFING BOX	ASTM A126 CLASS B
14	PACKING	NON ASBESTOS
15	GLAND FOLLOWER	ASTM A536 65-45-12
16	PACKING GLAND	ASTM B584
17	HANDWHEEL	ASTM A126 CLASS B
18	IDENTIFICATION PLATE	ALUMINUM
19	WASHER	ASTM A307-B
20	HANDWHEEL NUT	ASTM A307-B

DIMENSIONS:

SIZE		W		H		L		D		T	
IN	MM	IN	MM	IN	MM	IN	MM	IN	MM	IN	MM
2"	50	7.00	177.8	11.00	280	7	178	6.00	152	0.63	15.9
2-1/2"	65	7.50	190.5	12.50	318	7	178	7.00	178	0.69	17.5
3"	80	8.00	203.2	13.13	333	8	203	7.50	190	0.75	19.1
4"	100	9.00	228.6	15.25	387	10	254	9.00	229	0.94	23.8
5"	125	10.00	254.0	17.81	453	12	305	10.00	254	0.94	23.8
6"	150	10.50	266.7	19.75	502	12	305	11.00	279	1.00	25.4
8"	200	11.50	292.1	25.00	635	13.7	347	13.50	343	1.13	28.6
10"	250	13.00	330.2	28.94	735	16	406	16.00	406	1.19	30.2
12"	300	14.00	355.6	34.44	875	18	457	19.00	483	1.25	31.8
14"	350	15.00	381.0	37.00	940	20	508	21.00	533	1.38	35.0
16"	400	16.00	406.4	42.50	1080	22	558	23.50	597	1.43	36.6

DUE TO CONTINUOUS DEVELOPMENT OF OUR PRODUCTS, WE RESERVE THE RIGHT TO MODIFY OUR PRODUCT DESIGN OR CONSTRUCTION WITHOUT PRIOR NOTICE.