

The Best Products, The Best Service...

SERVICE METAL

ONE CALL GETS IT ALL



Welding Laterals – VERSION #2

STANDARD WEIGHT AND EXTRA STRONG

Inches / Pounds

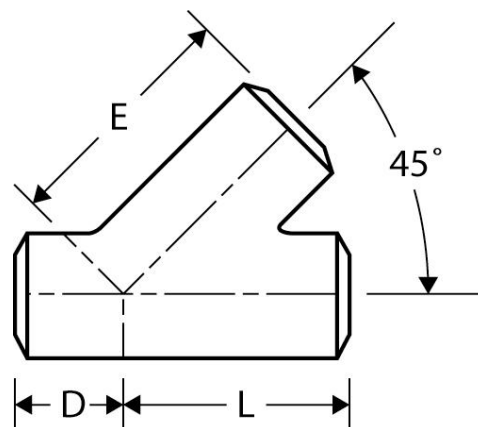

Nominal Pipe Size	SCH 40 (STD WALL)		SCH 80 (XS WALL)		Approximate Weight (in Pounds)	
	Dimensions		Dimensions		Standard Wall	Extra Strong
	E AND L	D	E AND L	D		
1	5.75	1.75	6.50	2	1.1	1.4
1 ¼	6.25	1.75	7.25	2.25	1.7	2.3
1 ½	7	2	8.50	2.50	2.5	3.4
2	8	2.50	9	2.50	4.0	5.6
2 ½	9.50	2.50	10.50	2.50	7.3	9.7
3	10	3	11	3	10.2	13.9
3 ½	11.50	3	12.50	3	13.2	18.1
4	12	3	13.50	3	15.9	22.2
5	13.50	3.50	15	3.50	26.8	38.3
6	14.50	3.50	17.50	4	38	58
8	17.50	4.50	20.50	5	69	107
10	20.50	5	24	5.50	114	154
12	24.50	5.50	27.50	6	166	219
14	27	6	31	6.50	218	289
16	30	6.50	34.50	7.50	288	381
18	32	7	37.50	8	361	479
20	35	8	40.50	8.50	435	580
24	40.50	9	47.50	10	613	817

** The working pressure of any fabricated lateral must be rated at only 40% of the allowable working pressure established for the pipe from which the lateral is being made.*